

POLE DESIGN LOADING						
Load Component	Height (ft.)	Weight (lbs.)	Ice Area (sq. ft.)	Wind Area (Face) (sq. ft.)	Wind Area (Side) (sq. ft.)	Fatigue Area (Bottom) (sq. ft.)
1 = Luminaire	0.5	25	8.1	0.6	1.0	2.5
2 = Signal	4.5	54	2.9	8.7	4.8	1.4
3 = Signal	5.6	70	37.5	11.0	6.4	1.4
4 = Ped Head	1.4	22	7.8	2.2	0.8	0.9
5 = Sign	2.5	120	69.7	30.0	0.8	4.0

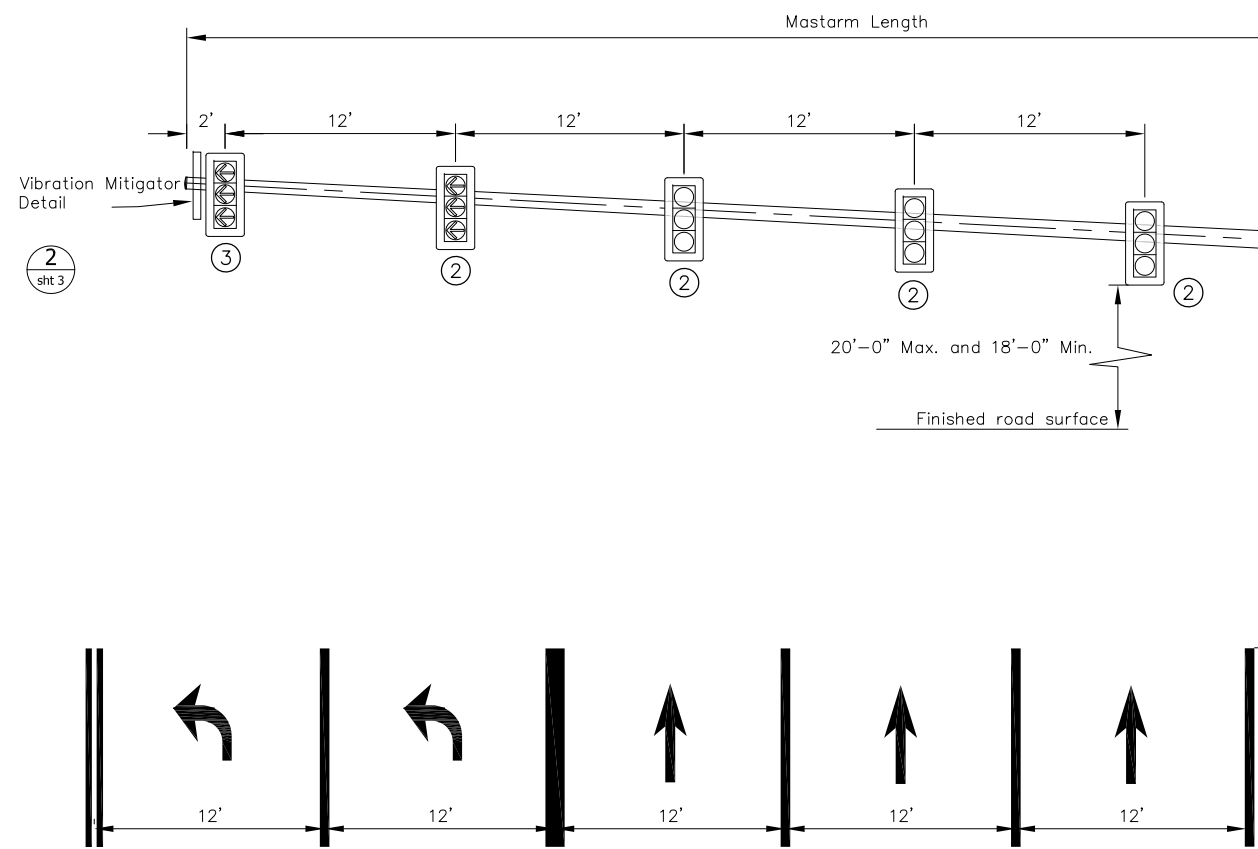
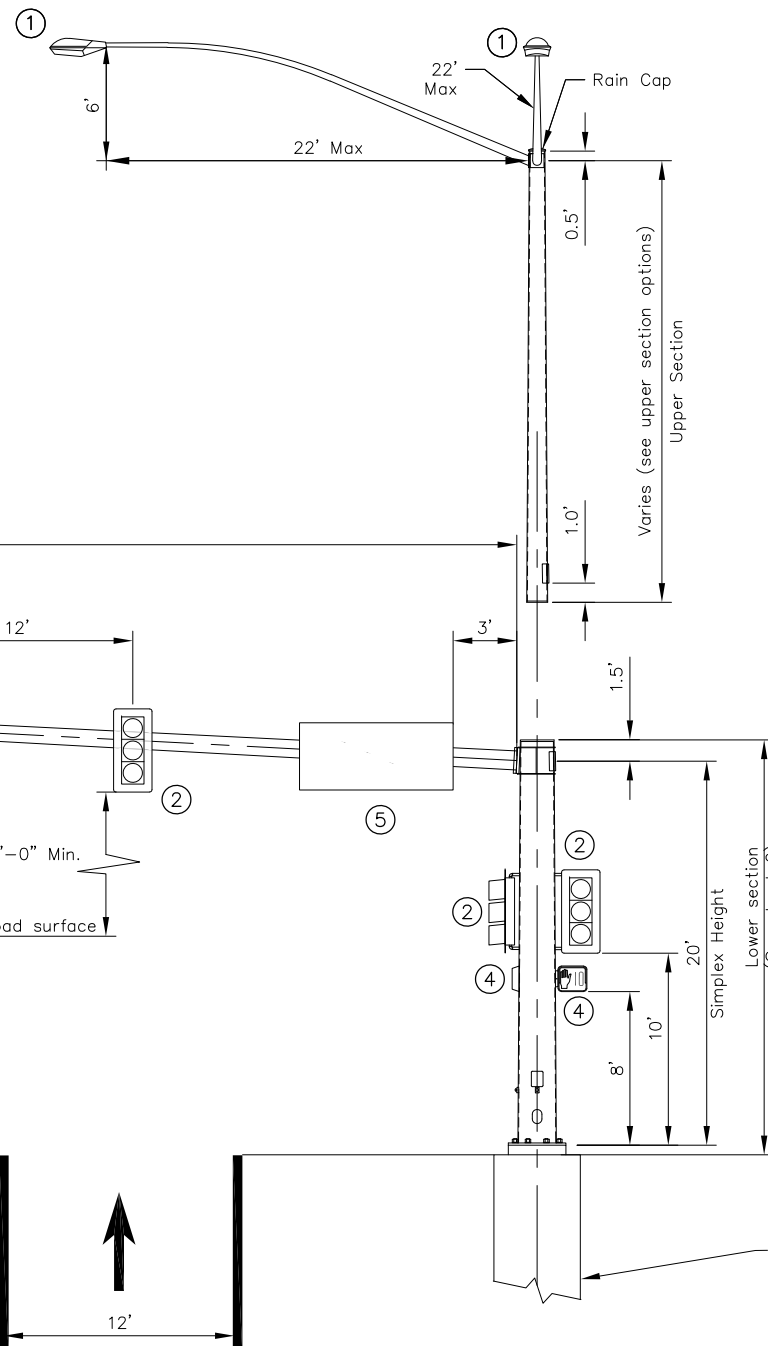

**ELEVATION VIEW**  
NTS

MASTARM DATA									
MASTARM		MASTARM END SECTION			MASTARM BASE SECTION			MASTARM BASEPLATE	
Length (ft.)	Maximum Allowed Galloping Deflection (in.)	Free End Diameter (in.)	Length (ft.)	Tube Thickness (in.)	Length (ft.)	Fixed End Diameter*	Tube Thickness (in.)	Plate Opening Diameter (in.)	Plate Thickness (in.)
70	12.0	7.5	40.0	0.1793	32.9	16.7	0.375	11.0	2.25
75	12.0	7.5	40.0	0.1793	37.9	17.4	0.375	11.0	2.25

\*Fixed end diameter measured at connection to Baseplate

**NOTES:**

- Provide pole assemblies designed, manufactured and installed according to: 2013 AASHTO Standard Specifications for Structural Supports for Highway Signs, Luminaires and Traffic Signals with 2013 Errata and 2015 Interim Revision, the latest edition of the Alaska Standard Specifications for Highway Construction including standard modifications, and special provisions. Design structures for a 50-year Design Life, Fatigue Category I with ice loading, and with a basic wind speed of 100 mph. Fatigue design shall include Natural Wind Gust, Truck-Induced Gust, and an approved vibration mitigating device in lieu of Galloping effect.
- Provide poles to accommodate the maximum length shown in the mastarm data with the given loads, dimensions, and material requirements.
- This drawing shows loads (signs and signals) to be used by manufacturers when designing poles. It does not show actual loading of poles/mastarms on individual projects. This pole/mastarm design may be used without further analysis if the following conditions are met:
  - The guide sign (load #5) is attached to the mastarm base section and,
  - Not more than 5 traffic signals and/or signs are attached to the mastarm.
 If these conditions are not met, this standard pole/mastarm design may only be used if design computations are submitted that demonstrate conformance to design criteria (note 1) using actual loads. Devices with less than 1 square foot of projected area may be added to the mastarm without causing a need for additional design computations.
- The manufacturer is to determine weld sizes. All welds and testing shall conform to the latest edition of the structural welding code AWS D1.1. Provide visual testing (VT) of 100% of all welds. Provide magnetic particle testing (MT) of 100% of all fillet welds. Provide radiographic (RT) or ultrasonic testing (UT) of 100% of all complete joint penetration welds and a random 25% of all partial joint penetration longitudinal seam welds.
- Fabricate pole tubes and mastarm tubes from no more than 2 pieces of steel. When using 2 pieces, place the longitudinal welded seams directly opposite one another. Transverse weld seams prohibited.
- Fabricate luminaire arms and connections according to the latest lighting standard detail.
- Provide permanent tags on all pole sections per section 740 table 740-1 of the specifications. Provide a weather proof rain cap on all exposed sections of the structure.
- The Department will reject damaged or defective poles for any of the following; variances from approved shop drawings, variances from material requirements, sections more than 2-percent out of round, flanged mounting surfaces with flatness variation greater than 0.030", sections bowed more than 1-inch throughout the length of the pole, mastarm, or segment, and damaged or dented finishes.
- To allow for wiring, field drill a 1" maximum diameter hole at each traffic signal head location. Orient the hole on the horizontal axis of mastarms.
- Install pole raked outward from plumb position in the direction opposite the mastarm such that the side of the pole opposite the mastarm is vertical.
- Clean and remove dirt, burrs, mill scale, and excess galvanization on all faying surfaces and threaded parts before assembly. Lubricate the threads of all bolts and nuts with lubricant containing a visible dye. Tighten all bolts according to section 504 of the specifications.

See Std. Plan for  
48" Signal Pole  
Foundation  
or Signal Pole Pipe  
Pile Foundation

State of Alaska DOT&PF  
ALASKA STANDARD PLAN

**SIGNAL POLE  
WITH 70' TO 75' MASTARM  
LOADING & NOTES**

Adopted as an Alaska  
Standard Plan by: *Carolyn H. Morehouse*  
Carolyn Morehouse, P.E.  
Chief Engineer

Adoption Date: 9/15/2022

Last Code and Stds. Review  
By: Date: 5/13/2021

Next Code and Standards Review date: 5/13/2031



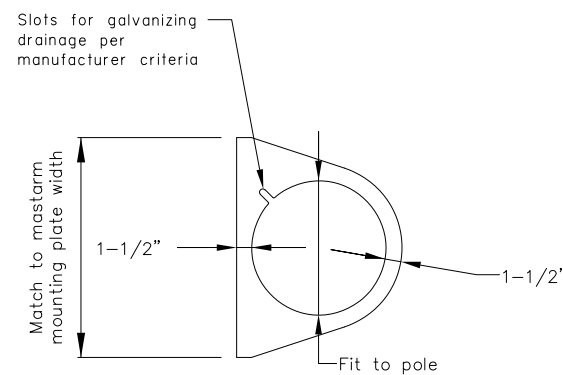

**RING DETAIL**

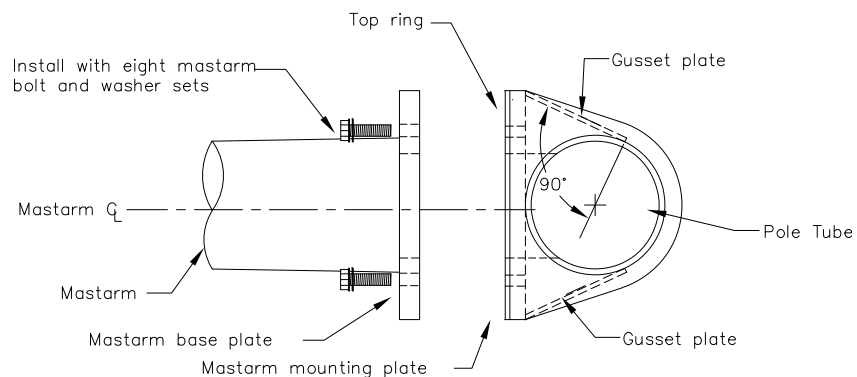

**SECTION B-B**

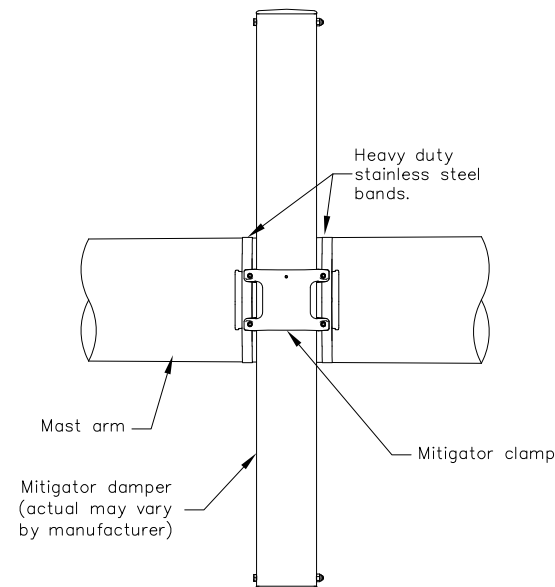

**2 VIBRATION MITIGATOR CONNECTION DETAIL**

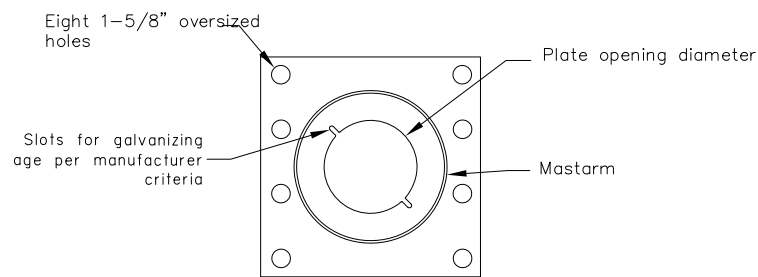

**MASTARM BASE PLATE**

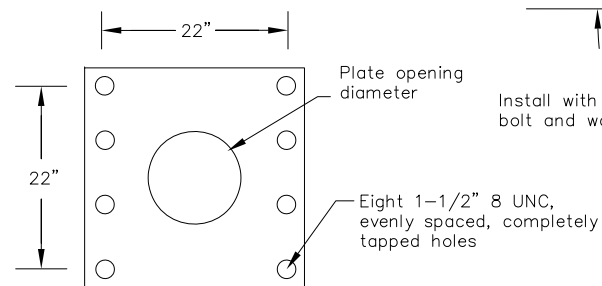

**MASTARM MOUNTING PLATE**

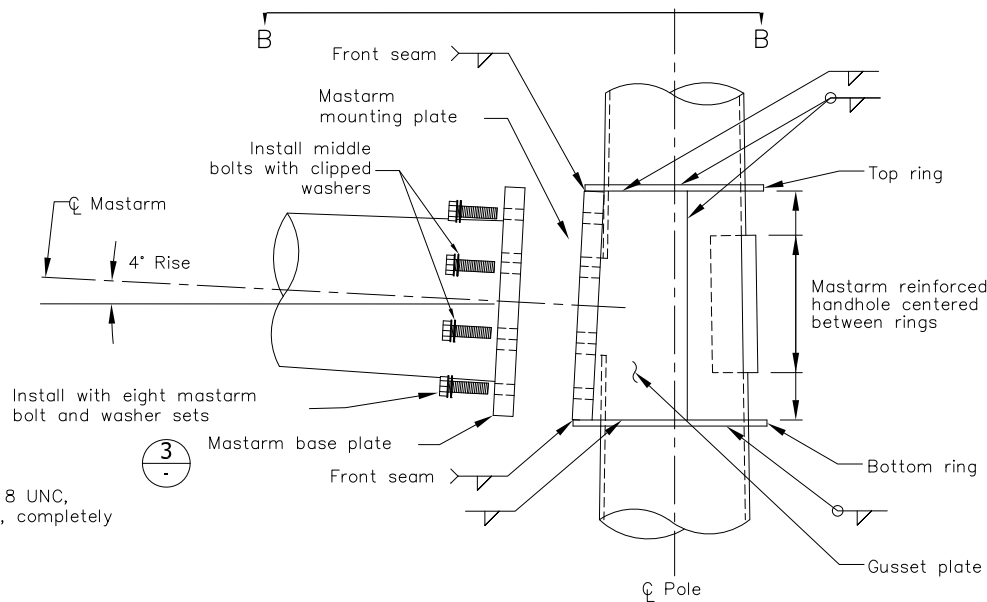

**SIDE VIEW**

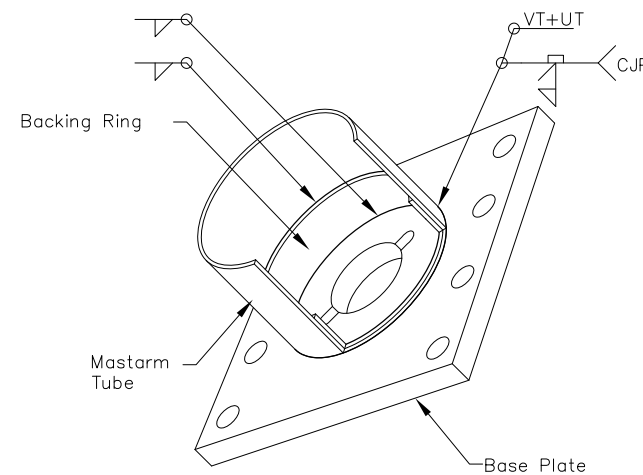

**ISO VIEW**

**TUBE TO TRANSVERSE PLATE WELD DETAIL**

(Shown with tube and backing ring cutout for clarity)

**1 RING - STIFFENED BOX DETAILS**

NTS

**3**

MATERIAL REQUIREMENTS	
MATERIAL QUALITY GUIDANCE	
Steel ≤ 1/2" Thick	ASTM A572 OR A595
Steel > 1/2" Thick	ASTM A709 (50ksi - Zone 3)
Finish	ASTM A123 & A153
Mastarm Bolts	ASTM F3125
Mastarm Washers	ASTM F436
Anchor Rods	See T-53
RING-STIFFENED BOX	
Mastarm Mounting Plate	26" x 26" x 2.25"
Plate Opening Diameter	Mastarm Data (See Sheet 1)
Top Ring Thickness	0.375"
Bottom Ring Thickness	0.375"
Gusset Plate Thickness	0.375"
MASTARM HANDHOLE	
Outside Dimensions	7" x 12.89"
Reinforcing Material	0.5" x 3"
Handhold Cover	0.125"
MASTARM	
Design Length	75'
Section Shape	Round
Plate Opening Diameter	Mastarm Data (See Sheet 1)
Mastarm Tube Thickness	Mastarm Data (See Sheet 1)
Fixed End Diameter	Mastarm Data (See Sheet 1)
Mastarm Rise	4.0 degrees
Mastarm Baseplate	26" x 26" x 2.25"
Backing Ring	0.25" x 3"
Mastarm Bolts	1.5" 6 UNC x 5.5"

State of Alaska DOT&PF  
ALASKA STANDARD PLAN  
**SIGNAL POLE  
WITH 70' TO 75' MASTARM  
MASTARM & STIFFENED BOX**

Adopted as an Alaska Standard Plan by: *Carolyn H. Morehouse*

Carolyn Morehouse, P.E.  
Chief Engineer

Adoption Date: 9/15/2022

Last Code and Sids. Review  
By: Date: 5/13/2021

Next Code and Standards Review date: 5/13/2031

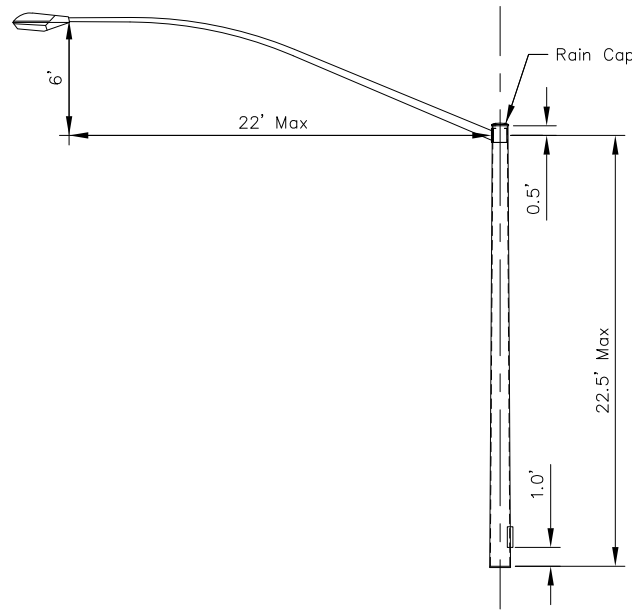

**SINGLE LUMINAIRE**

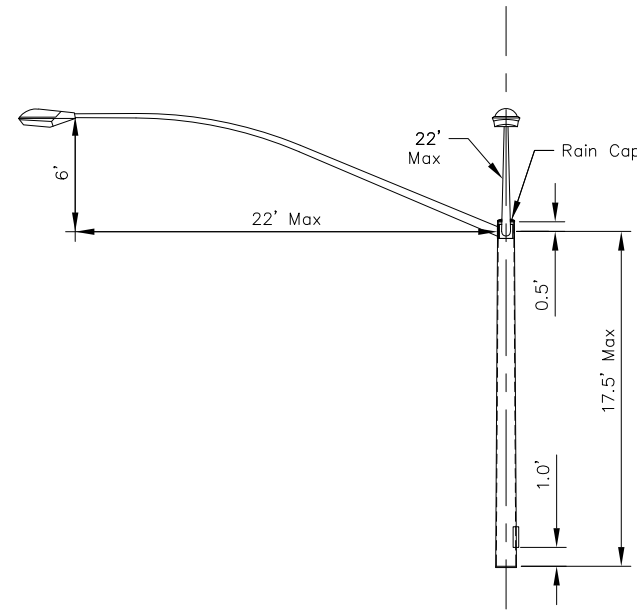

**DOUBLE LUMINAIRE**

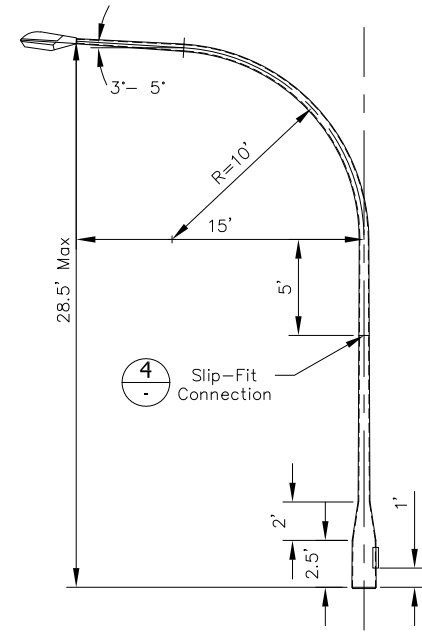

**DAVIT LUMINAIRE**

**UPPER SECTION OPTIONS**  
NTS

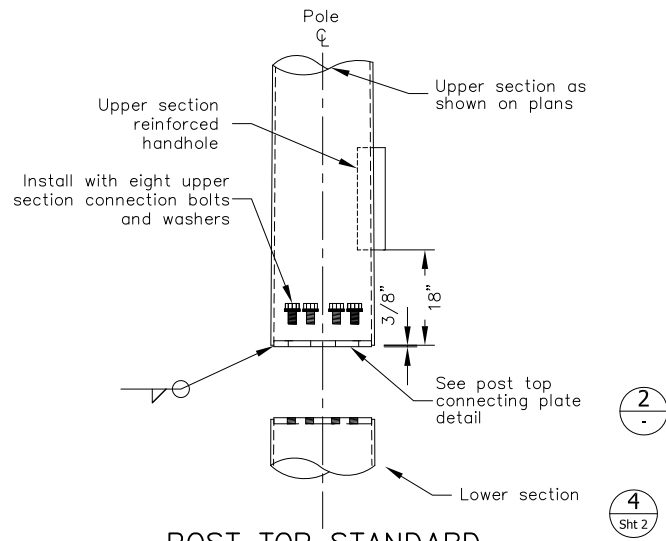

**POST TOP STANDARD UPPER SECTION BASE DETAIL**

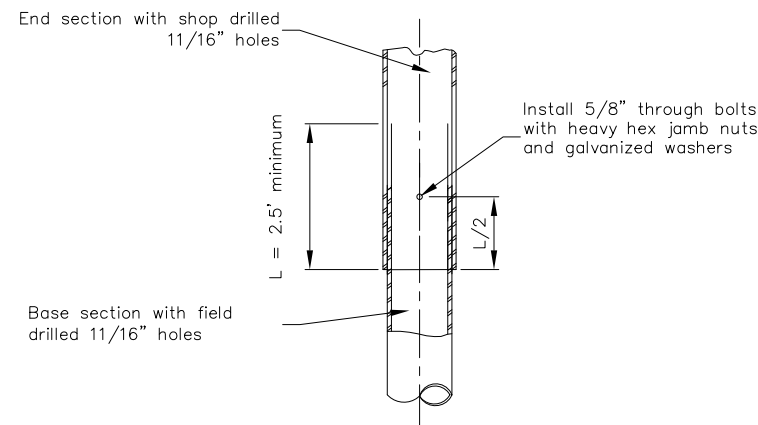

**MASTARM SLIP SPLICE ELEVATION DETAIL**  
NTS

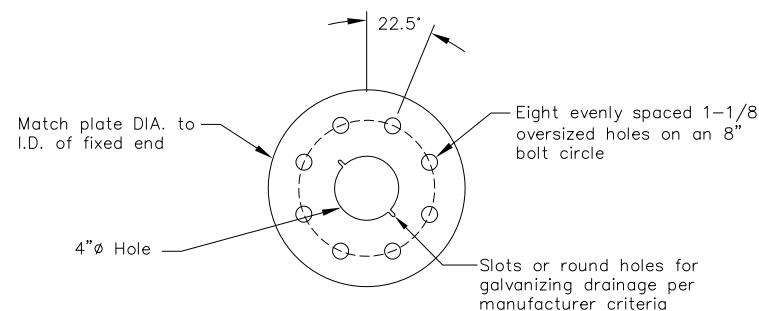

**POST TOP CONNECTING PLATE DETAIL**

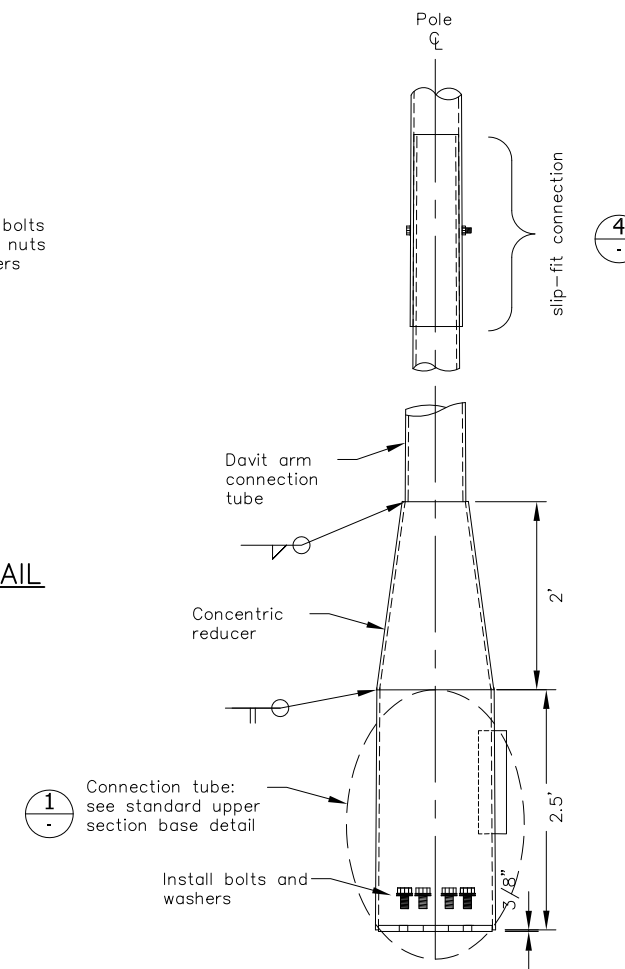

**DAVIT UPPER SECTION BASE DETAIL**  
NTS

MATERIAL REQUIREMENTS	
MATERIAL QUALITY GUIDANCE	
Tube Material	A572, A595 GR A, or A1011 (50ksi min)
Post Top Connecting Plates	ASTM A709 (Zone 3)
Concentric Reducer	A572 OR A595 GR A
Connection Tube	A572 OR A595 GR A
Luminaire, Arm, and Mounting	See Lighting Standard Details
Upper Section Connection Bolts	ASTM F3125
Upper Section Connection Bolts	ASTM F436
Slip Fit Through Bolt	ASTM F3125
Finish	ASTM A123 & A153
STANDARD UPPER SECTION	
Fixed End Diameter	17.99" O.D.
Taper	0.14"/ft
Connecting Plate Thickness	1"
Post Top Connection Bolts	1" 8 UNC x 2.75"
Tube Thickness	7 GA
HANDHOLE DIMENSIONS	
Upper Section Handhole	7" x 12.89"
Reinforcing Material	0.5" x 3"
Handhole Cover	0.125"
SINGLE LUMINAIRE	
Design Length	22.5'
Section Shape	Round
DOUBLE LUMINAIRE	
Design Length	17.5'
Section Shape	Round
DAVIT LUMINAIRE	
Design Length	28.5'
Section Shape	Round
Taper	0.14'/ft
Free End Diameter	2.375" O.D.
Connection Tube	7 GA
Concentric Reducer	7 GA
Davit Arm Connection Tube	7 GA
Davit Arm	7 GA

State of Alaska DOT&PF  
ALASKA STANDARD PLAN

**SIGNAL POLE WITH 70' TO 75' MASTARM UPPER SECTION**

Adopted as an Alaska Standard Plan by: *Carolyn H. Morehouse*  
Carolyn Morehouse, P.E.  
Chief Engineer

Adoption Date: 9/15/2022

Last Code and Stds. Review By: Date: 5/13/2021

Next Code and Standards Review date: 5/13/2031